

Mentype[®] Argus Y-MH^{QS} PCR Amplification Kit

Product description

The Mentype[®] Argus Y-MH^{QS} PCR Amplification Kit is a multiplex application for the nine Y-chromosomal Short Tandem Repeat (STR) loci of the **Minimal Haplotype (MH)** standard. The primers of **DYS19**, **DYS385ab**, **DYS389-I**, **DYS389-II**, **DYS390**, **DYS391**, **DYS392**, and **DYS393** are fluorescence-labelled with **6-FAM** or **HEX**.

The test kit was developed specifically for fast and reliable generation of male DNA profiles from mixtures of male and female DNA up to a **ratio of 1:6000** so that separation of sperm from female cells or differential lysis is not required. The detection limit of the Mentype[®] Argus Y-MH^{QS} PCR Amplification Kit is up to **100 pg genomic male DNA**. However, it is recommended to use **0.1-1.0 ng male DNA**.

As special feature, Mentype[®] Argus Y-MH^{QS} contains an **internal PCR control** (Quality Sensor "QS") which provides helpful information on the efficiency of the PCR and on the presence of PCR inhibitors.

The Mentype[®] Argus Y-MH^{QS} was developed according to the recommendations of the International Forensic Y-User Group (<http://www.yhrd.org/index.html>). This consortium has evaluated a core set of a highly informative Y-STR, the so called *Minimal Haplotype* which was recommended for court. Generation of DNA profiles using Mentype[®] Argus Y-MH^{QS} corresponds to the guidelines of the International Society for Forensic Genetics (Gill et al., 2001 a and b; Gusmão et al., 2005a). All important population-genetic data could be calculated with the GenoProof[®] Software.

The test kit was validated and evaluated using the GeneAmp[®] 9700 thermal cycler, ABI PRISM[®] 310 Genetic Analyzer, and ABI PRISM[®] 3100/3130 Genetic Analyzer.

Table 1. Locus-specific information of Mentype[®] Argus Y-MH^{QS}

STR Locus	GenBank[®] accession	Repeat motif of the reference allele	Reference allele	Allele range
DYS19	AC017019	[TAGA] ₃ TAGG [TAGA] ₁₂	15	9-19
DYS385	AC022486	[GAAA] ₁₁	11	6-28
DYS389-I	AC004617	[TCTG] ₃ [TCTA] ₉	12	9-17
DYS389-II	AC004617	[TCTG] ₅ [TCTA] ₁₂ [TCTG] ₃ [TCTA] ₉	29	24-35
DYS390	AC011289	[TCTG] ₈ [TCTA] ₁₁ [TCTG] ₁ [TCTA] ₄	24	12, 17-29
DYS391	AC011302	[TCTA] ₁₁	11	5-16
DYS392	AC011745	[TAT] ₁₃	13	4-20
DYS393	AC006152	[AGAT] ₁₂	12	7-18

Table 1 shows the STR loci with their repeat motifs and alleles. The most frequent alleles for European populations are included in the allelic ladder. Allele ranges include all known alleles of YHRD (<http://www.yhrd.org> as at 12/2008) and of the current literature.

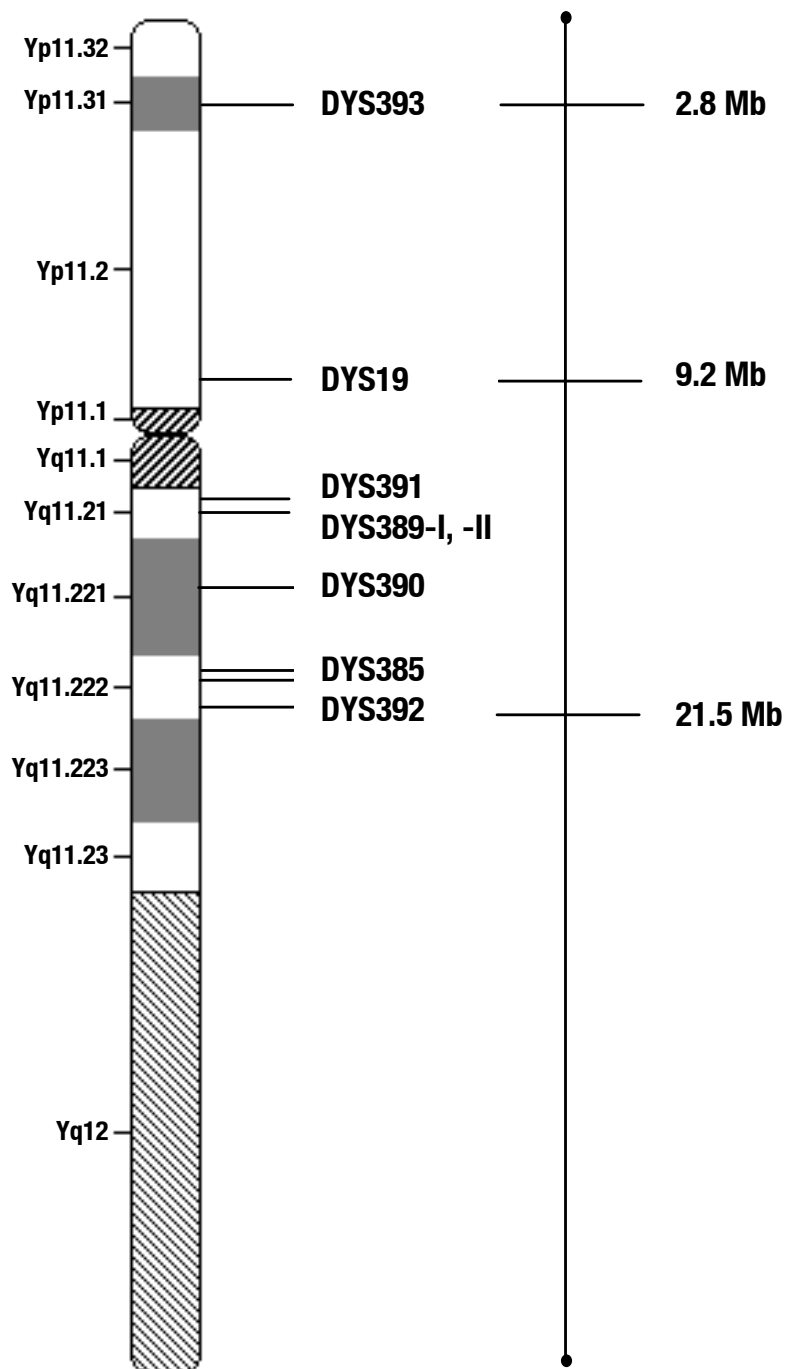

Fig. 1 The ideogram of the Y-chromosome describes the physical localisation of the STR loci which can be analysed with Mentype® Argus Y-MH^{QS}. The positions of the STR loci are shown in Mb (<http://www.ncbi.nlm.nih.gov/genome/guide/human> as at 08/2008).

Table 2. Chromosomal Mapping of Mentype® Argus Y-MH^{QS}

Locus	Chromosomal mapping
DYS19	Yp11.2
DYS385	Yq11.222
DYS389-I	Yq11.21
DYS389-II	Yq11.21
DYS390	Yq11.221
DYS391	Yq11.21
DYS392	Yq11.222
DYS393	Yp11.31

Content**Mentype® Argus Y-MH^{QS} PCR Amplification Kit (100 Reactions)**

Nuclease-free water	3.0 mL
Reaction mix B	500 µL
Primer mix	250 µL
DNA polymerase	40 µL
Control DNA XY1 (2 ng/µL)	10 µL
Control DNA XX (50 ng/µL)	10 µL
DNA Size Standard 550 (ROX)	50 µL
Allelic ladder	10 µL

Ordering information

Mentype® Argus Y-MH ^{QS}	25 reactions	Cat. No.	42-09112-0025
Mentype® Argus Y-MH ^{QS}	100 reactions	Cat. No.	42-09112-0100
Mentype® Argus Y-MH ^{QS}	400 reactions	Cat. No.	42-09112-0400

Storage

Store all components at -20°C and avoid repeated thawing and freezing. Primer mix and allelic ladder must be stored protected from light. The DNA samples and post-PCR reagents (allelic ladder and DNA size standard) should be stored separately from the PCR reagents. The expiry date is indicated on the kit cover.

Quality assurance

All kit components undergo an intensive quality assurance process at Biotype Diagnostic GmbH. The quality of the test kits is permanently monitored in order to ensure unrestricted usability. Please contact us if you have any questions regarding quality assurance.

Additionally required reagents

Additional reagents are needed in order to use the Biotype[®] PCR Amplification Kit:

Reagent	Supplier	Order number
Hi-Di [™] Formamide, 25 mL	Applied Biosystems	4311320
Matrix Standards DS-30 for ABI PRISM [®] 310 Genetic Analyzer	Applied Biosystems	401546 und 402996 (NED)
Matrix Standards DS-30 for ABI PRISM [®] multi-capillary instruments	Applied Biosystems	4345827

Trademarks and patents

Mentype[®] is a registered trademark of Biotype Diagnostic GmbH.

GenoProof[®] is a registered trademark of Qualitytype AG.

ABI PRISM[®], GeneScan[®], Genotyper[®], GeneMapper[™] and Applied Biosystems are registered trademarks of Applied Biosystems Inc. or its subsidiaries in the U.S. and certain other countries.

6-FAM, HEX, NED, ROX, POP-4 and Hi-Di are trademarks of Applied Biosystems Inc.

GeneAmp[®] is a registered trademark of Roche Molecular Systems.

The PCR is covered by patents. Patentees are Hoffmann-La Roche Inc. and

F. Hoffmann-La Roche (Roche).

GenBank[®] is a trademark of National Institute of Health.

Warnings and safety instructions

The PCR Amplification Kit contains the following potentially hazardous chemicals:

Kit component	Chemical	Hazards
Primer mix, reaction mix and allelic ladder	Sodium azide NaN ₃	toxic if swallowed, develops toxic gases when it gets in contact with acids

Observe the Material Safety Data Sheets (MSDS) for all Biotype[®] products, which are available on request. Please contact the respective manufacturers for copies of the MSDS for any additionally needed reagents.

Content

1. PCR amplification.....	6
1.1 Master mix preparation	6
1.2 PCR amplification parameter	7
2. Electrophoresis using the ABI PRISM [®] 310 Genetic Analyzer	8
2.1 Matrix generation.....	8
2.2 Sample preparation.....	11
2.3 Setting up the GeneScan [®] software	11
2.4 Analysis parameter	12
3. Electrophoresis using the ABI PRISM [®] 3130/3130xl Genetic Analyzer.....	13
3.1 Spectral calibration / matrix generation	13
3.2 Sample preparation.....	16
3.3 Setting up the GeneMapper [™] ID software	17
3.4 Analysis parameter / analysis method	19
4. Analysis.....	20
4.1 Biotype [®] template files.....	22
4.2 Controls	23
4.3 Lengths of fragments and alleles	23
5. Interpretation of results	28
6. References	29

Protocols for PCR amplification, electrophoresis, and analysis

1. PCR amplification

1.1 Master mix preparation

The table below shows the volumes of all PCR reagents per 25 µL reaction volume, including a sample volume of 1.0 µL (template DNA). The number of reactions to be set up shall be determined taking into account positive and negative control reactions. Add one or two reactions to this number to compensate the pipetting error.

Component	Volume
Nuklease-free water	16.1 µL
Reaction mix B *	5.0 µL
Primer mix	2.5 µL
Multi Taq2 DNA Polymerase (hot start, 2.5 U/µL)	0.4 µL
Volume of master mix	24.0 µL

* contains Mg²⁺, dNTPs, BSA

All components should be mixed (vortex) and centrifuged for about 10 s before preparing the master mix. The DNA volume applied to the assay depends on its concentration. A volume of up to 5 µL may be necessary for DNA trace templates. DNA volumes of more than 5 µL are not recommended, because potential PCR inhibitors may interfere with the process. Fill up the final reaction volume to 25 µL with nuclease-free water.

Generally, DNA templates shall be stored in nuclease-free water or in diluted TE buffer (10 mM Tris HCl, pH 8.0 and 1 mM EDTA), e.g. 0.1x TE buffer.

The primer mixes are adjusted for balanced peak heights at **30 PCR cycles** and **0.5 ng Control DNA XY1** in a reaction volume of 25 µL. If more DNA template is introduced, higher peaks can be expected for small PCR fragments and relatively low peaks for large fragments. Reduce the amount of DNA template to correct this imbalance.

Positive control

For the positive amplification control, dilute the Control DNA XY1 to 0.5 ng in the appropriate volume. Instead of the template DNA, pipette the diluted Control DNA into a reaction tube containing the PCR master mix.

Negative control

For the negative amplification control, pipette nuclease-free water instead of template DNA into a reaction tube which contains the PCR master mix.

1.2 PCR amplification parameter

Perform a “hot start” PCR in order to activate the Multi Taq2 DNA Polymerase and to prevent the formation of non-specific amplification products.

The number of cycles depends on the amount of DNA. 30 cycles are recommended for all samples. For critical stains (< 100 pg DNA), it is recommended to increase the number of PCR cycles from 30 to 34.

Standard method

Recommended for all DNA samples

Temperature	Time	
94°C	4 min (hot start for activation of the Multi Taq2 DNA Polymerase)	
94°C	30 s	
58°C	120 s	30 cycles
72°C	75 s	
68°C	60 min	
10°C	∞	hold

Optional

Recommended for stains with small amounts of genomic DNA

Temperature	Time	
94°C	4 min (hot start for activation of the Multi Taq2 DNA Polymerase)	
94°C	30 s	
58°C	120 s	34 cycles
72°C	75 s	
68°C	60 min	
10°C	∞	hold

Too Small amounts of DNA may result in allelic dropouts and imbalances of the peaks. Furthermore, unspecific amplification products could appear. With increasing numbers of cycles, there is the risk of cross contamination caused by minimal amounts of impurities.

2. Electrophoresis using the ABI PRISM® 310 Genetic Analyzer

For general instructions on instrument setup, matrix generation and application of the GeneScan® or GeneMapper™ ID software, refer to the *ABI PRISM® 310 Genetic Analyzer User's Manual*. Electrophoresis using the GeneScan® software is described below.

The virtual **filter set D** shall be used for combined application of the four fluorescent labels **6-FAM**, **HEX**, **NED**, and **ROX** (also called **DS-30**). Generally, Filter Sets A and F are suitable, too.

Material

Capillary	47 cm / 50 µm (green)
Polymer	POP-4 for 310 Genetic Analyzer
Buffer	10x Genetic Analyzer Buffer with EDTA

2.1 Matrix generation

Prior to conducting DNA fragment size analysis with the filter set D, a matrix with the four fluorescent labels 6-FAM, HEX, NED, and ROX must be generated. The suitable matrix standard **DS-30** is available from Applied Biosystems.

Colour	Matrix standard	Order number
Blue (B)	6-FAM	Applied Biosystems, 401546
Green (G)	HEX	Applied Biosystems, 401546
Yellow (Y)	NED	Applied Biosystems, 402996
Red (R)	ROX	Applied Biosystems, 401546

Four electrophoresis runs shall be conducted, one for each fluorescent label, 6-FAM, HEX, NED, and ROX, under the same conditions as for the samples and allelic ladders of the Biotype® test kit to generate suitable matrix files.

Matrix sample	Component	Volume
Matrix sample 1	Hi-Di™ Formamide	12.0 µL
	Matrix standard 6-FAM	1.0 µL
Matrix sample 2	Hi-Di™ Formamide	12.0 µL
	Matrix standard HEX	1.0 µL
Matrix sample 3	Hi-Di™ Formamide	12.0 µL
	Matrix standard NED	1.0 µL
Matrix sample 4	Hi-Di™ Formamide	12.0 µL
	Matrix standard ROX	1.0 µL

- Denaturation for 3 min at 95°C
- Cool down to 4°C
- For analysis: load the samples on the tray

- Create a **Sample Sheet** and enter sample designation

Injection list for matrix generation

Parameter	Set up
Module File	GS STR POP-4 (1 mL) D
Matrix File	NONE
Size Standard*	NONE
Injection [s]	5
Injection [kV]	15.0
Run [kV]	15.0
Run [°C]	60
Run Time [min]	24

* prepare matrix standards always **without DNA Size Standard (ROX)**

Analysis of the matrix samples

- Run the GeneScan® software
- **File** → **New** → **Project** (open folder of current run) → **Add Sample Files**
- Select a matrix sample in the **Sample File** column
- **Sample** → **Raw Data**
- Check the matrix samples regarding a flat baseline. As shown in the figure below, there should be at least five peaks with peak heights about 400-4000 (Y-axis) for each matrix sample (optimal range: 1000-3000)

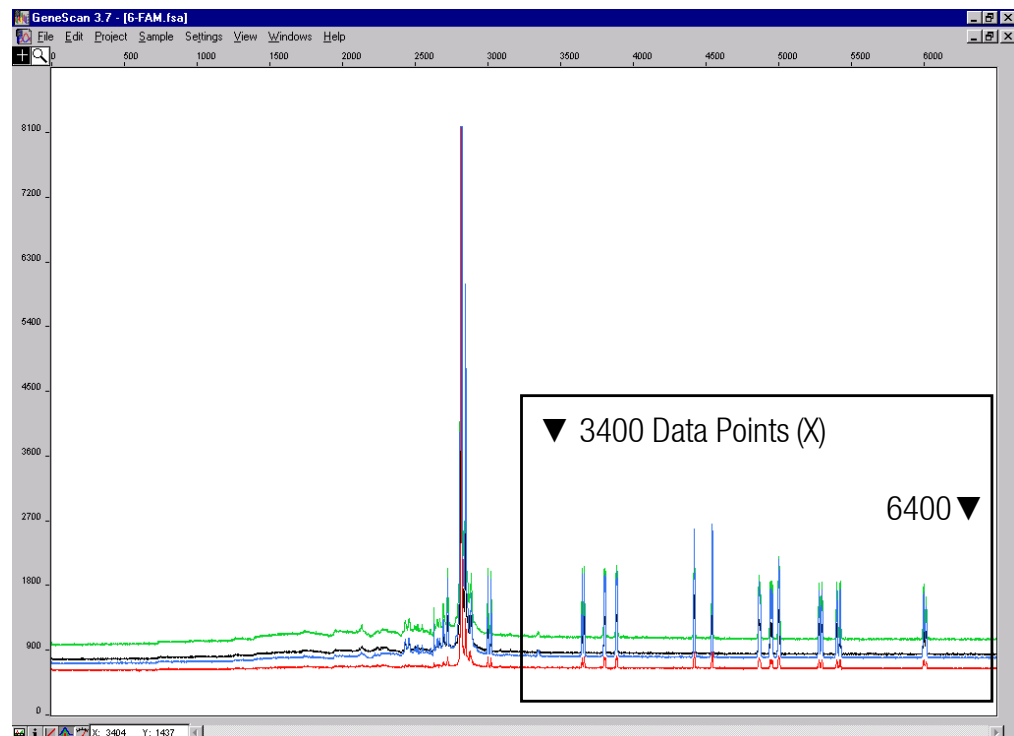

Fig. 2 Electropherogram with raw data of the matrix standard 6-FAM

- Select analysis range with flat baseline and re-inject the matrix sample if necessary
- Note down start and end value (data points) of the analysis range, e.g. start value 3400, end value 6400
- Calculate the difference, e.g. $6400 - 3400 = 3000$ data points

Generation of a new matrix

- **File** → **New** → **Matrix**

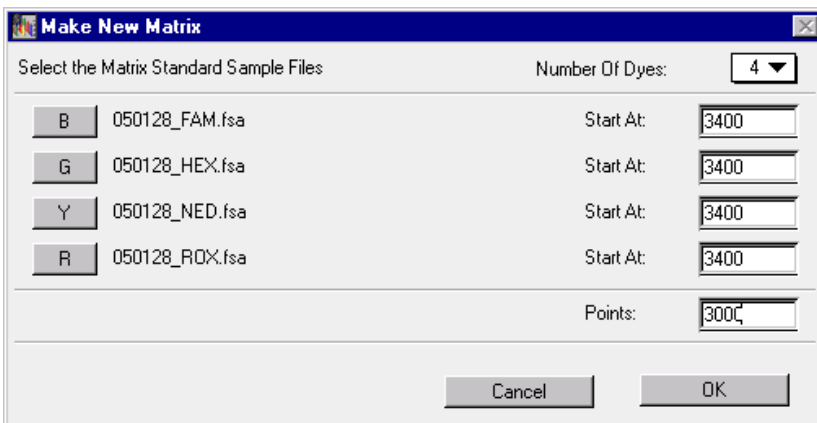

Fig. 3 Matrix sample selection

- Import matrix samples for all dyes (B, G, Y, R)
- Enter a **Start At** value, e.g. 3400
- Enter the calculated difference under **Points**, e.g. 3000
- Click on **OK** to calculate the new matrix

	Reactions			
	B	G	Y	R
B	1.0000	0.4164	0.0415	0.0012
G	0.8472	1.0000	0.6863	0.0107
Y	0.4509	0.4886	1.0000	0.0456
R	0.1273	0.1792	0.4964	1.0000

Fig. 4 New matrix DS-30

- Save the matrix in the matrix folder: **File** → **Save as**, e.g. Matrix DS-30

Matrix check

Check the new matrix with current samples.

- **File** → **New** → **Project** (open folder of the respective run) → **Add Sample Files**
- Select sample(s) in the **Sample File** column
- **Sample** → **Install New Matrix** (open matrix folder and select new matrix)
- Re-analyse your samples

There should be **no** pull-up peaks between the dye panels (B, G, Y, R) with the new matrix.

2.2 Sample preparation

Component	Volume
Hi-Di™ Formamide	12.0 µL
DNA Size Standard 550 (ROX)	0.5 µL

prepare 12 µL of the mix (formamide + DNA size standard) for all samples
add 1 µL PCR product (diluted if necessary) or allelic ladder

- Denaturation for 3 min at 95°C
- Cool down to 4°C
- For analysis: load the samples on the tray

Signal intensities

Options to increase the signal intensity:

- Reduce the volume of the DNA Size Standard 550 (ROX) to peak heights of about 500 relative fluorescent units (RFU)
- Purify the PCR products before starting the analysis

2.3 Setting up the GeneScan® software

- Create a **Sample sheet** and enter sample designation

Injection list

Parameter	Set up
Module File	GS STR POP-4 (1 mL) D
Matrix File	e.g. Matrix Biotype
Size Standard	e.g. SST-ROX_50-400bp
Injection [s]*	5
Injection [kV]	15.0
Run [kV]	15.0
Run [°C]	60
Run Time [min]**	26

* Deviating from standard settings, the injection time may range between 1 and 10 s depending on the type of sample. If blood samples with very high signal intensities are recorded, a shorter injection time may be selected. For samples with low DNA content an injection time up to 10 s may be necessary.

** Depending on the analysis conditions the run time for Mentype® **Argus Y-MH^{QS}** was modified in order to analyse fragments with lengths of up to **400 bp**.

2.4 Analysis parameter

The recommended analysis parameters are:

Analysis Range	Start: 2000 Stop: 10000
Data Processing	Baseline: Checked Multicomponent: Checked Smooth Options: Light
Peak Detection	Peak Amplitude Thresholds B:* Y:* G:* R:* Min. Peak Half Width: 2 pts Polynomial Degree: 3 Peak Window Size: 11 pts**
Size Call Range	Min: 50 Max: 550
Size Calling Method	Local Southern Method
Split Peak Correction	None

* The peak amplitude threshold (cutoff value) corresponds to the minimum peak height that will be detected by the GeneScan® or GeneMapper™ ID software. Thresholds are usually 50-200 RFU and should be determined individually by the laboratory. Recommendation: The minimal peak height should be three times as high as the background noise of the baseline.

** Point alleles (i.e. alleles with at least 1 bp difference to the next integer allele) may occasionally not be distinguished. For improved peak detection, minimise the Peak Window Size further.

3. Electrophoresis using the ABI PRISM® 3130/3130xl Genetic Analyzer

For detailed instructions on instrument setup, spectral calibration, or application of the ABI PRISM® Data Collection software version 3.0 and the GeneMapper™ ID software, refer to the *ABI PRISM® 3130/3130xl Genetic Analyzers Getting Started Guide*.

The system with 4 capillaries is named ABI 3130 (former ABI 3100-Avant), and the system with 16 capillaries is named ABI 3130xl (former ABI 3100).

The virtual **filter set D** shall be used for combined application of the four fluorescent labels **6-FAM**, **HEX**, **NED**, and **ROX** (also called **DS-30**).

Material

Capillary	36 cm Capillary Array for 3130/3130xl
Polymer	POP-4 Polymer for 3130
Buffer	10x Genetic Analyzer Buffer with EDTA

3.1 Spectral calibration / matrix generation

Prior to conducting DNA fragment size analysis, it is necessary to perform a spectral calibration with the four fluorescent labels 6-FAM, HEX, NED, and ROX for each analyzer. The calibration procedure creates a matrix which is used to correct the overlapping of fluorescence emission spectra of the dyes.

Spectral calibration comprises the following steps:

- Preparation the spectral calibration standards
- Loading the standards to the 96-well reaction plate (one sample per capillary)
- Creating the instrument protocol for spectral calibration (Protocol Manager)
- Defining the plate composition in the plate editor (Plate Manager)
- Performing a spectral calibration run and checking the matrix

Setting up the spectral calibration standards

Example for 4 capillaries/ABI 3130

Component	Volume
Hi-Di™ Formamide	47.5 µL
Matrix standard DS-30	2.5 µL

- Load 12 µL of the mix to a 96-well reaction plate, e.g. position **A1-D1**
- Denaturation for 3 min at 95°C
- Cool down to 4°C

Example for 16 capillaries/ABI 3130xl

Component	Volume
Hi-Di™ Formamide	190.0 µL
Matrix standard DS-30	10.0 µL

- Load 12 µL of the mix to a 96-well reaction plate, e.g. position **A1-H1** and **A2-H2**
- Denaturation for 3 min at 95°C
- Cool down to 4°C

Performing a spectral calibration run

- Insert the 96-well plate on the autosampler tray
- In the **Protocol Manager** of the Data Collection Software click **New** the window **Instrument Protocol** to open the **Protocol Editor** dialog box

Instrument Protocol for spectral calibration

Protocol Editor	Set up
Name	User (e.g. Spectral36_POP4_DS30)
Type	SPECTRAL
Dye Set	D
Polymer*	User (e.g. POP4)
Array Length*	User (e.g. 36cm)
Chemistry	Matrix Standard
Run Module*	Default (e.g. Spect36_POP4_1)

* Depends on the type of polymer and length of capillary used

- Select **OK** to complete the **Protocol Editor** dialog box
- In the **Plate Manager** of the Data Collection software click **New** to open the **New Plate Dialog** box

Plate Editor for spectral calibration (I)

New Plate Dialog	Set up
Name	e.g. Spectral_DS-30_date
Application	Spectral Calibration
Plate Type	96-Well
Owner Name / Operator Name	...

- Select **OK**. A new table in the **Plate Editor** opens automatically

Plate Editor for spectral calibration (II)

Parameter	Set up
Sample Name	Type name for the matrix samples
Priority	e.g. 100
Instrument Protocol 1	Spectral36_POP4_DS30 (setting described before)

- Click into the column header to select the entire column, select **Edit** → **Fill Down** to apply the information to all selected samples, and click on **OK**
- In the **Run Scheduler** click on **Find All**, select **Link** to link the reaction plate on the autosampler up with the newly created plate record (position A or B) and start the run

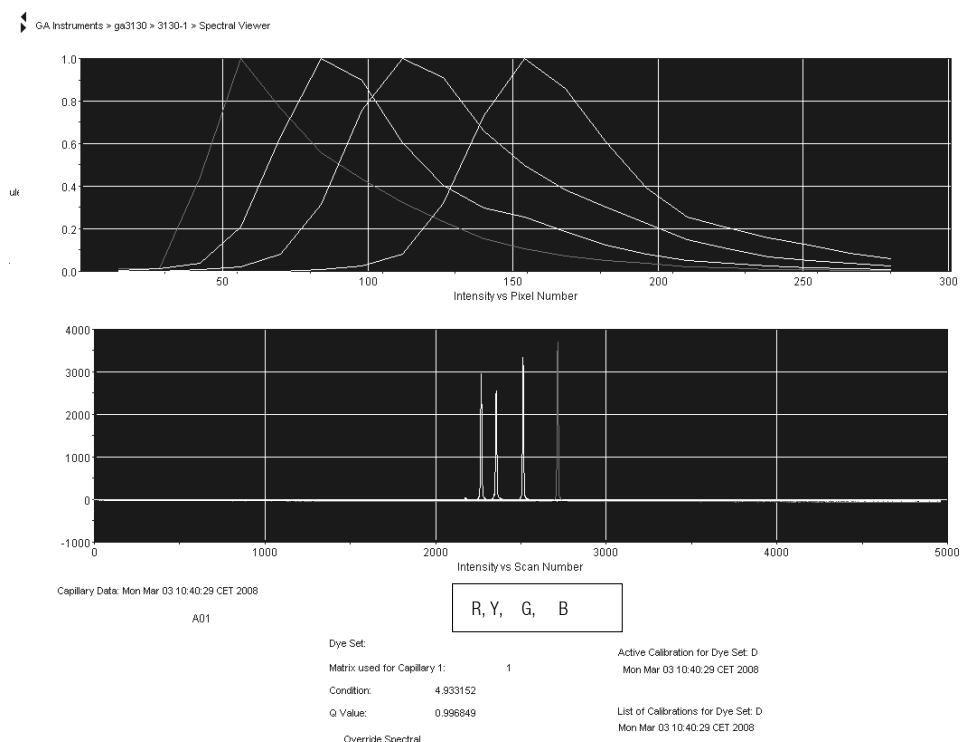

Fig. 5 Electropherogram of spectral calibration with matrix standard DS-30 on an ABI 3130

Matrix check

- The quality value (**Q value**) of each capillary must be greater than 0.95 and the condition number range (**C value**) must be between 1 and 20.
- Check the matrix samples for a flat baseline. As shown in the figure above, there should be four peaks with peak heights of about 1000-5000 (Y-axis) in each matrix sample (optimal range: 2000-4000)
- Check the new matrix with your current samples. There should be **no** pull-up peaks between the dye panels (B, G, Y, R, O) with the new matrix
- If calibration was not successful, use the optimised values and repeat the calibration run
- If all capillaries have passed the test, the last calibration file for the **Dye Set D** is activated automatically in the **Spectral Viewer**. **Rename** the calibration file (e.g. DS-30_Date of calibration) using the respective button

3.2 Sample preparation

Component	Volume
Hi-Di™ Formamide	12.0 µL
DNA Size Standard 550 (ROX)	0.5 µL

prepare 12 µL of the mix (formamide + DNA size standard) for all samples
add 1 µL PCR product (diluted if necessary) or allelic ladder

-
- Denaturation for 3 min at 95°C
 - Cool down to 4°C
 - For analysis: load the samples on the tray

Since injections take place simultaneously on all capillaries, 4 or 16 samples must be pipetted on the plate of multi-capillary analysers. If fewer samples are analysed, the empty positions must be filled with 12 µL Hi-Di™ Formamide.

To ensure a reliable allelic assignment on multi-capillary analysers, a number of allelic ladders should be run, independently from sample number.

Room temperature may influence the performance of PCR products on multi-capillary instruments, so that shoulder peaks or split peaks occur especially at low temperatures. Pay attention to keeping ambient conditions as recommended by the instrument manufacturer..

Signal intensities

Options to increase the signal intensity:

- Reduce the volume of the DNA Size Standard 550 (ROX) to peak heights of about 500 relative fluorescent units (RFU)
- Purify the PCR products before starting the analysis

3.3 Setting up the GeneMapper™ ID software

Edit the Run Module as follows for the first run:

- In the **Module Manager** of the Data Collection software click on **New** to open the **Run Module Editor** dialog box

Run Module 3kV_10s_400bp

Parameter	Set up
Oven Temperature [°C]	Default
Poly Fill Volume	Default
Current Stability [µA]	Default
PreRun Voltage [kV]	Default
PreRun Time [s]	Default
Injection Voltage [kV]	3.0
Injection Time [s]*	10
Voltage Number of Steps	Default
Voltage Step Interval	Default
Data Delay Time [s]	Default
Run Voltage [kV]	Default
Run Time [s]**	1200

* Deviating from the standard settings, the injection time may range between 1 and 20 s depending on the type of sample. If samples with very high signal intensities are recorded, a shorter injection time may be selected. For samples with low DNA content an injection time of up to 20 s may be necessary.

** Depending on the analysis conditions the run time for Mentype® **Argus Y-MH^{QS}** was modified in order to be able to analyse fragments with lengths of up to **400 bp**.

- Click on **Save As**, enter the name of the new module (e.g. 3kV_10s_400bp) and confirm with **OK**
- Click on **Close** to exit the **Run Module Editor**

Starting the run

- Place the prepared 96-well plate on the autosampler tray
- In the **Protocol Manager** of the Data Collection software, click on **New** in the **Instrument Protocol** window to open the **Protocol Editor** dialog box

Instrument Protocol

Protocol Editor	Set up
Name	e.g. Run36_POP4_DS-30_20min
Type	REGULAR
Run Module*	3kV_10s_400bp
Dye Set	D

* parameter see above

- Click on **OK** to exit the **Protocol Editor**

Prior to each run, it is necessary to create a plate definition as follows:

- In the **Plate Manager** of the Data Collection software click on **New** to open the **New Plate Dialog** box

GeneMapper™ Plate Editor (I)

New Plate Dialog	Set up
Name	e.g. Plate_DS-30_Date
Application	select GeneMapper Application
Plate Type	96-Well
Owner Name / Operator Name	...

- Click **OK**. A new table in the **Plate Editor** opens automatically

GeneMapper™ Plate Editor (II)

Parameter	Set up
Sample Name	Type name for the samples
Priority	e.g. 100 (Default)
Sample Type	Sample or Allelic Ladder
Size Standard	e.g. SST-ROX_50-400bp
Panel	e.g. Biotype_Panels_v3a (choose test kit)
Analysis Method	e.g. Analysis_HID_3130
Snp Set	-
User-defined 1-3	-
Results Group 1	(select results group)
Instrument Protocol 1	Run36_POP4_DS-30 (setting described earlier)

- Click into the column header to select the entire column, select **Edit** → **Fill Down** to apply the information to all selected samples and click on **OK**
- In the **Run Scheduler**, click on **Find All**, select **Link** to link the reaction plate on the autosampler up with the newly created plate record (position A or B) and start the run
- During the run, view **Error Status** in the **Event Log** or examine the quality of the raw data for each capillary in the **Capillaries Viewer** or the **Cap/Array Viewer**
- View data as overview in **Run History** or **Cap/Array Viewer** of the Data Collection software. Run data are saved in the **Run Folder** of the previously chosen **Result Group**

3.4 Analysis parameter / analysis method

The recommended settings in the worksheet Peak Detector are:

Peak Detection Algorithm	Advanced
Ranges	Analysis: Partial Range Start Pt: 2000; Stop Pt: 10000 Sizing: All Sizes
Smoothing and Baselineing	Smoothing: Light Baseline Window: 51 pts
Size Calling Method	Local Southern Method
Peak Detection	Peak Amplitude Thresholds B:* Y:* G:* R:* Min. Peak Half Width: 2 pts Polynomial Degree: 3 Peak Window Size: 11 pts** Slope Thresholds: 0.0

* The peak amplitude threshold (cutoff value) corresponds to the minimum peak height that will be detected by the GeneMapper™ ID software. The thresholds are usually 50-200 RFU and should be determined individually by the laboratory. Recommendation: The minimal peak height should be three times as high as the background noise of the baseline.

** Point alleles (i.e. alleles with at least 1 bp difference to the next integer allele) may occasionally not be distinguished. For improved peak detection, minimise the Peak Window Size further.

4. Analysis

For general instructions on automatic sample analysing, refer to the *GeneScan®* or *GeneMapper™ ID Software User's Manual*.

Finding the exact lengths of the amplified products depends on the device type, the conditions of electrophoresis, as well as the DNA size standard used. Due to the complexity of some loci, determining the size should be based on evenly distributed references. The DNA Size Standard 550 (ROX) shall thus be used with the following lengths of fragments: **50, 60, 70, 80, 90, 100, 120, 140, 160, 180, 190, 200, 220, 240, 260, 280, 300, 320, 340, 360, 380, 400, 425, 450, 475, 500, 525, and 550 bp.**

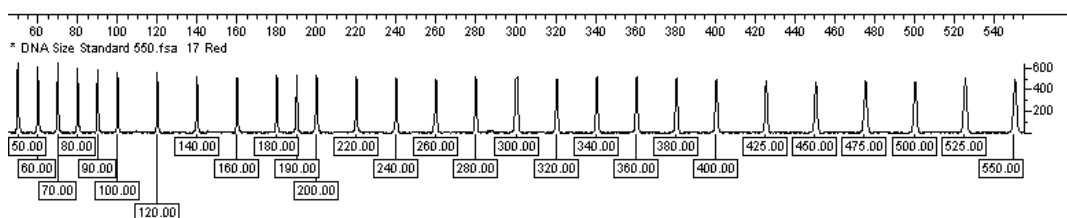

Fig. 6 Electropherogram of the DNA Size Standard 550 (ROX), fragments with lengths in bp

Note: The basic template files for the DNA Size Standard 550 (ROX) has to be adjusted to 400 bp within the GeneMapper™ ID software. The new template could be saved as e.g. SST-ROX_50-400bp and used for further analyses.

As mentioned before, Mentype® **Argus Y-MH^{QS}** contains an **internal PCR control** (Quality Sensor), which provides helpful information on the efficiency of the PCR and on presence of PCR inhibitors. A 6-FAM labelled **81 bp**-fragment is amplified independently of the DNA. The PCR control assay without DNA shows only the sensor fragment (Fig. 7) and indicates successful polymerase chain reaction.

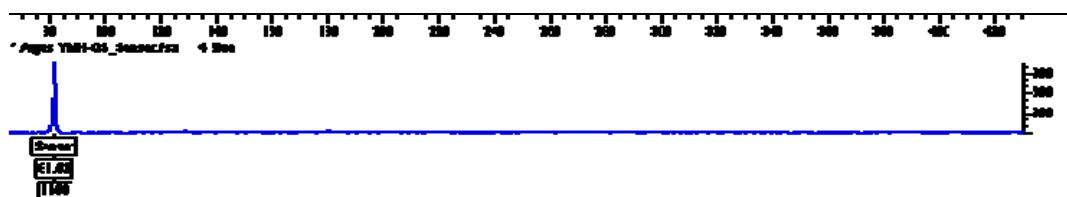

Fig. 7 Electropherogram of the 6-FAM labelled PCR control fragment (Quality Sensor). Fragment length in bp, signal intensities in peak height

Special features

In general, the electropherogram displays a single peak for each Y-STR locus. However, locus **DYS385** produces two peaks of different or same length. These two fragments originate from duplicated and inversed copies of one Y-chromosomal locus. The primers provided in the test kit simultaneously co-amplify the two homologous loci. For separate amplification, see Kittler et al., 2003.

Concerning locus **DYS385** it must be stressed that alleles 14.3, 15.3, 16.3, 17.3, and 19.3 represent the alleles 15, 16, 17, 18, and 20, respectively, with one thymidine deletion between the primer binding site and the repeat region (Füredi et al., 1999). This deletion may serve as an additional distinctive feature for differentiation in forensic casework.

If more than one peak is obtained in the electropherogram for one or several markers, this does not necessarily hint at mixed samples. Duplications or triplications of STR markers also result in such an effect and have already been observed for **DYS385** and **DYS19** (Butler et al., 2005). Rarely, single systems can fail too because of Y-chromosomal deletions as known in azoospermic patients, as already described for **DYS385** and **DYS392** (Stein et al., 2005).

Mutation rates for intermediate or infrequent alleles of the Y-STR system of the Mentype® **Argus Y-MH^{QS}** test kit varies between $0,613 \times 10^{-3}$ and $5,296 \times 10^{-3}$ (Gusmão et al., 2005b).

Allele frequencies of the **European Minimal Haplotype Standard** are collected and published by the Biotype Diagnostic GmbH (Rodig et al., 2007). They can be received as download from our homepage (www.biotype.de). Furthermore, there is free access to the “Y-Chromosome Haplotype Reference Database” from the International Forensic Y-User Group (<http://www.yhrd.org/index.html>) in order to calculate frequencies oneself.

4.1 Biotype[®] template files

Allele allocation should be carried out with a suitable analysis software, e.g. GeneMapper[™] ID or Genotyper[®] software in combination with the Mentype[®] **Argus Y-MH^{QS}** template files from Biotype. Template files are available from our homepage or as CD-ROM on request.

Recommended Biotype[®] templates for GeneMapper[™] ID/ID-X software are:

Panels	Biotype_Panels_v3a/v3X (choose kit)	or higher versions
BinSets	Biotype_Bins_v3a/v3X	or higher versions
Size Standard	SST-ROX_50-500bp (adjust up to 400bp, adjustment described earlier)	
Analysis Method	Analysis_HID_310	
	Analysis_HID_3130	
	Analysis_HID_310_50rfu	
	Analysis_HID_3130_50rfu	
Plot Settings	Plots_3dyes	
Table Settings	Table for 2 alleles	
	Table for 10 alleles	

Panels and BinSets always have to be used whereas the other template files are optional.

Additional Biotype[®] templates for GeneMapper[™] ID-X Software:

Stutter*	Biotype_Stutter_v3X	or higher version
----------	---------------------	-------------------

* When loading the above mentioned panels, the stutter settings will not be accepted. Thus, the stutter data has to be imported separately.

Recommended Biotype[®] template files for Genotyper[®] software are:

Argus_YMH-QS_v2c	or higher versions
------------------	--------------------

General procedure for the analysis

1. Check the DNA size standard
2. Check the allelic ladder
3. Check the positive control
4. Check the negative control
5. Analyse and interpret the sample data

4.2 Controls

The Control DNA XY1 of the test kit and other commercially available DNA from standard cell lines represent the following alleles:

Table 3. Allele determinations of Mentype® Argus Y-MH^{QS}

STR Locus	Control DNA XY1	Control DNA XX	ATCC K-562	CCR 9947	CCR 9948	CCR 3657
DYS19	13	-	-	-	14	13
DYS385ab	16 / 17	-	-	-	11 / 14	16 / 19
DYS389-I	13	-	-	-	13	12
DYS389-II	30	-	-	-	31	29
DYS390	24	-	-	-	24	24
DYS391	11	-	-	-	10	10
DYS392	11	-	-	-	13	11
DYS393	13	-	-	-	13	13

No PCR fragments are amplified with the Control DNA XX, but may be used to generate mixtures with the Control DNA XY1. The reference DNA K-562 is available from ATCC (<http://www.atcc.org/Products/PurifiedDNA.cfm#celllines>). For further confirmation, the table above displays the Y-chromosomal alleles of two reference DNAs purchased from Coriell Cell Repositories (CCR; <http://locus.umdj.edu/nigms>) that is up to the standard of Szibor et al., 2003.

4.3 Lengths of fragments and alleles

Table 4 to **table 5** show the fragment lengths of individual alleles that refer to the DNA Size Standard 550 (ROX). All analyses have been performed on an ABI PRISM® 310/3130 Genetic Analyzer with POP-4 polymer. Different analysis instruments, DNA size standards or polymers may result in different fragment lengths. In addition, a visual alignment with the allelic ladder is recommended.

Scaling

Horizontal: 85-405 bp (with Quality Sensor 75-405 bp)

Vertical: Depending on signal intensity

Figure 8

A

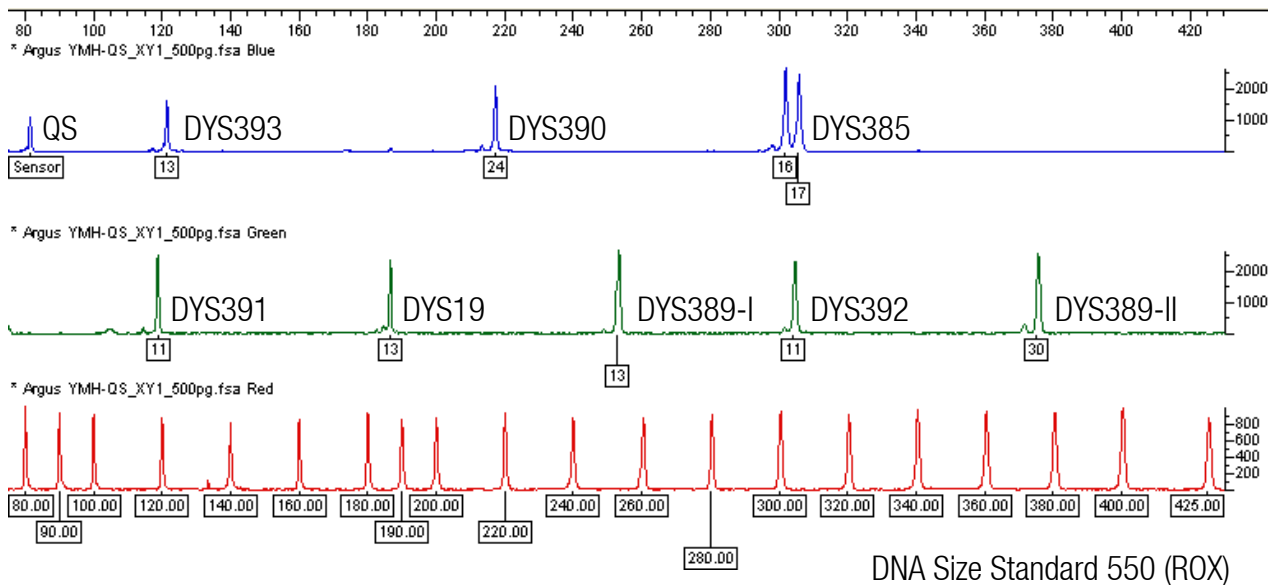

B

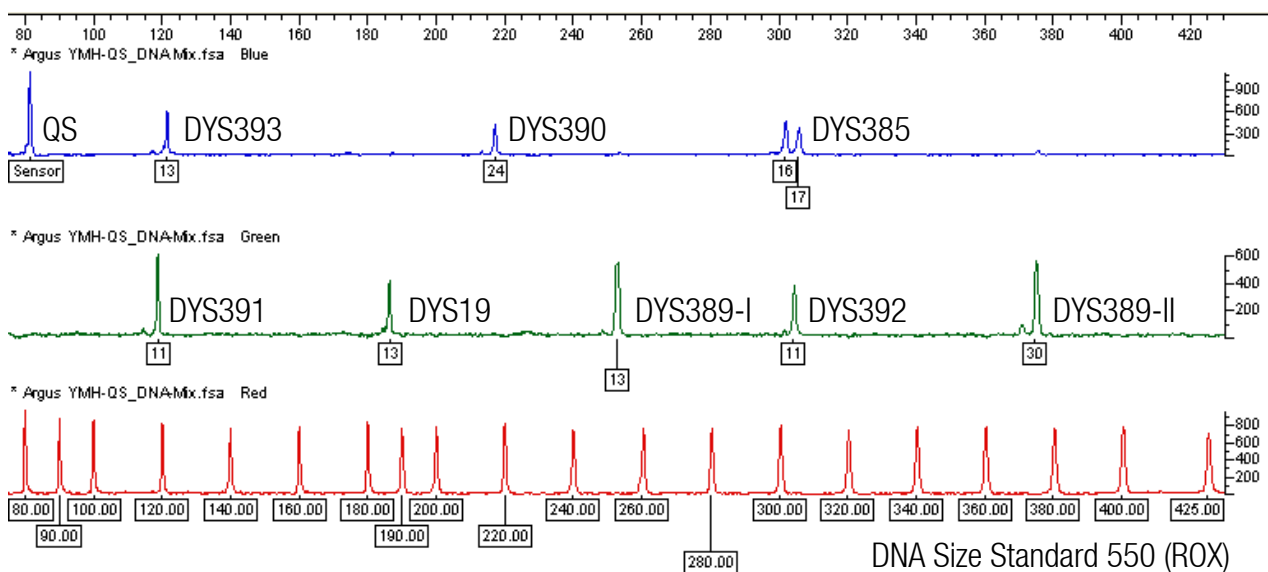

Fig. 8 Electropherogram of the Mentype® Argus Y-MH^{QS} using 500 pg Control DNA XY1 (**A**) or 100 pg male Control DNA XY1 mixed with 50 ng female Control DNA XX (**B**). The **Quality Sensor (QS)** is shown at 81 bp. Analysis was performed on an ABI PRISM® 310 Genetic Analyzer with the DNA Size Standard 550 (ROX). Allele assignment was performed using the Genotyper® software and the Mentype® Argus Y-MH^{QS} template file.

Figure 9

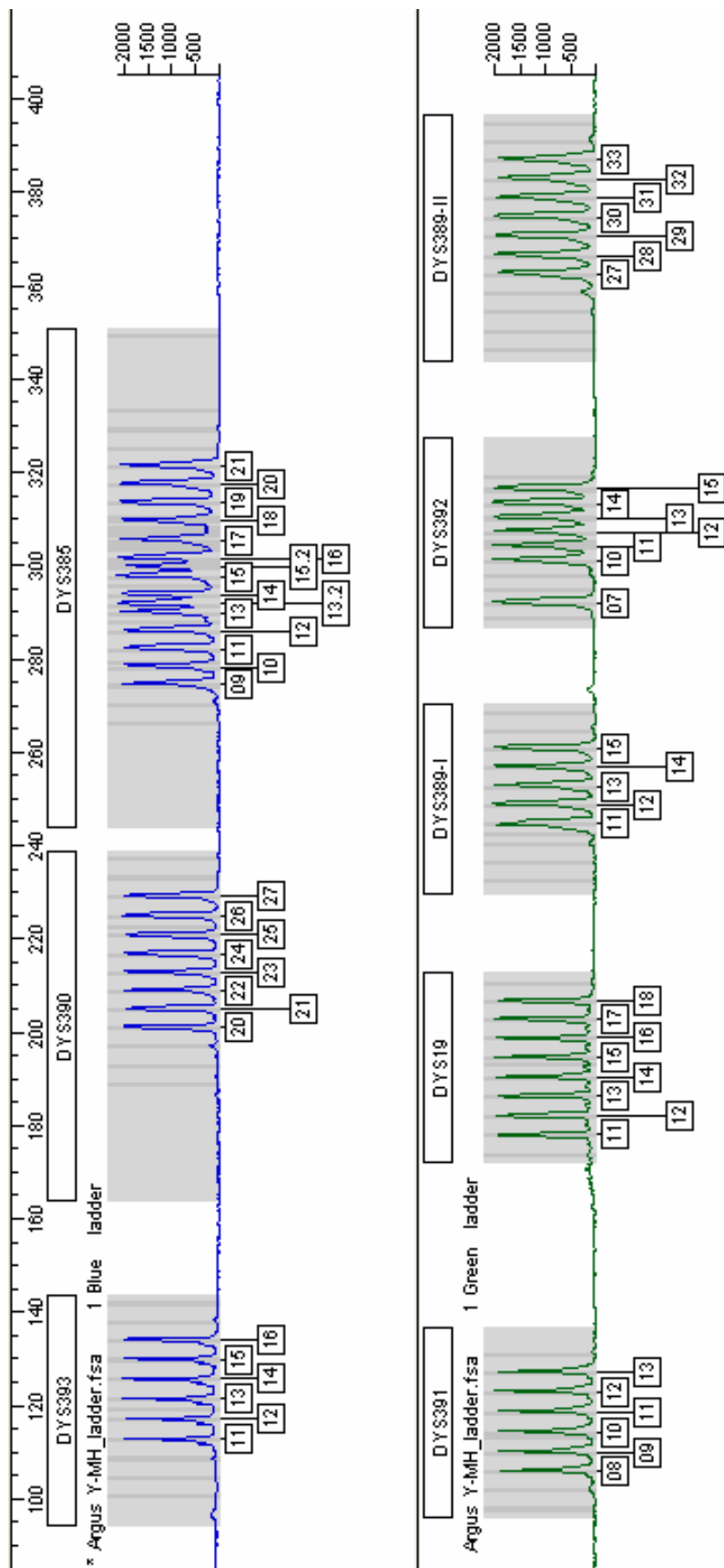

Fig. 9 Electropherogram of the allelic ladder Mentype® Argus Y-MH^{OS} analysed on an ABI PRISM® 310 Genetic Analyzer. Allele assignment was performed using the Genotyper® software and the Mentype® Argus Y-MH^{OS} template files.

Table 4. Fragment lengths of the allelic ladder Mentype® Argus Y-MH^{QS} analysed on an ABI PRISM® 310 Genetic Analyzer (blue panel)

Marker/allele	Size [bp]*	Further Allele**	Marker/allele	Size [bp]*	Further Allele**	Marker/allele	Size [bp]*	Further Allele**
PCR control	6-FAM		DYS390	6-FAM		DYS385	6-FAM	
Quality Sensor	81		20	201	17, 18, 19	9	274	7, 8
			21	205		10	278	10.1
			22	209		11	282	
DYS393	6-FAM		23	213		12	286	12.2
11	113	8, 9, 10	24	217	24.3	13	290	
12	117	12.2	25	221	25.2	13.2	292	
13	121		26	225		14	294	14.2, 14.3
14	126		27	230	28, 29	15	298	
15	130					15.2	300	15.3
16	134	17, 18				16	302	16.2, 16.3
						17	305	17.1, 17.2, 17.3
						18	309	18.1
						19	313	
						20	317	
						21	321	22, 23, 24, 25, 28

Table 5. Fragment lengths of the allelic ladder Mentype[®] Argus Y-MH^{QS} analysed on an ABI PRISM[®] 310 Genetic Analyzer (green panel)

Marker/allele	Size [bp]*	Further Allele**	Marker/allele	Size [bp]*	Further Allele**	Marker/allele	Size [bp]*	Further Allele**
DYS391	HEX		DYS389-I	HEX		DYS389-II	HEX	
8	106	6, 7	11	245	8, 9, 10, 10.2	27	363	23, 24, 25, 26
9	110	9.3	12	249		28	367	
10	114		13	253		29	371	
11	119		14	257		30	375	
12	123		15	261	16, 17	31	379	
13	127	14				32	383	
			DYS392	HEX		33	387	34, 35
DYS19	HEX		7	292	6, 8, 9			
11	178	10	10	301				
12	182		11	304	11.1			
13	186		12	307				
14	191	14.3	13	310				
15	195		14	313				
16	199		15	316	16, 17, 18			
17	203							
18	207	19						

* rounded to integer

** The "off-ladder" alleles of Biotype's DNA pool are allocated with the actual Biotype[®] template files for GeneMapper[™] ID or Genotyper[®] software. For further alleles see amongst others http://www.cstl.nist.gov/biotech/strbase/str_fact.htm or <http://www.yhrd.org>

5. Interpretation of results

As mentioned above, post PCR analysis and automatic allele assignment with suitable analysis software ensure a precise and reliable discrimination of alleles.

Pull-up peaks

Pull-up peaks may occur if peak heights are outside the linear detection range (>3000 RFU), or if an incorrect matrix was applied. They appear at positions of specific peaks in other colour channels, typically with lower signal intensities. Peak heights should not exceed 3000 RFU in order to prevent pull-up peaks.

Stutter peaks

The occurrence of stutter peaks depends on the sequence of the repeat structure and the number of alleles. n-4 peaks are caused by a loss of a repeat unit during amplification of tetranucleotide STR motives, caused by slippage effects of the Taq DNA Polymerase, whereas n+3 and n-3 peaks appear particularly during amplification of the trinucleotide STR motif DYS392 (Mulero et al, 2006). Those peaks should be interpreted in accordance with the template files of the Genotyper[®] and GeneMapper[™] ID software.

Template-independent addition of nucleotides

Because of its terminal transferase activity, the Taq DNA Polymerase tends to add an adenosine radical at the 3'-end of the amplified DNA fragments. The artefact peak is one base shorter than expected (-1 peaks). All Biotype[®] primers are designed to minimise these artefacts. Artefact formation is further reduced by the final extension step of the PCR protocol at 68°C for 60 minutes. Peak height of the artefact correlates with the amount of DNA. Laboratories should define their own limits for analysis of the peaks.

Quality Sensor to check the PCR results

Mentype[®] **Argus Y-MH^{QS}** contains an internal PCR check (Quality Sensor), which provides helpful information on the efficiency of the PCR and on presence of PCR inhibitors (see Fig. 7). Complete sensor failure indicates total inhibition of the PCR or errors in the assay. If the sensor signal is amplified in presence of DNA either in the negative control or in the positive control, the PCR is not inhibited. Samples with sufficient DNA and without inhibiting substances result in the DNA profile according to the kit and the sensor fragment. Reduced sensor peak heights in forensic samples indicate partial PCR inhibition. If only the Quality Sensor is amplified, the sample contains very little, only female or degraded DNA.

Artefacts

Room temperature may influence the performance of PCR products on multi-capillary instruments, so that shoulder peaks or split peaks occur. If shoulder or split peaks appear, we recommend injecting the sample again.

6. References

- Butler JM, Decker AE, Kline MC, Vallone PM (2005)** Chromosomal duplications along the Y-chromosome and their potential impact on Y-STR interpretation. *J. Forensic Sci.* 50(4): 1-7.
- Füredi S, Woller J, Padar Z, Angyal M (1999)** Y-STR haplotyping in two Hungarian populations. *Int. J. Legal Med.* 113(1): 38-42.
- Gill P, Brenner C, Brinkmann B, Budowle B, Carracedo A, Jobling MA, de Knijff P, Kayser M, Krawczak M, Mayr WR, Morling N, Olaisen B, Pascali V, Prinz M, Roewer L, Schneider PM, Sajantila A, Tyler-Smith C (2001a)** DNA commission of the International Society of Forensic Genetics: recommendations on forensic analysis using Y-chromosome STRs. *Int. J. Legal Med.* 114(6): 305-9.
- Gill P, Brenner C, Brinkmann B, Budowle B, Carracedo A, Jobling MA, de Knijff P, Kayser M, Krawczak M, Mayr WR, Morling N, Olaisen B, Pascali V, Prinz M, Roewer L, Schneider PM, Sajantila A, Tyler-Smith C (2001b)** DNA Commission of the International Society of Forensic Genetics: recommendations on forensic analysis using Y-chromosome STRs. *Forensic Sci. Int.* 124(1): 5-10.
- Gusmão L, Butler JM, Carracedo A, Gill P, Kayser M, Mayr WR, Morling N, Prinz M, Roewer L, Tyler-Smith C, Schneider PM (2005a)** DNA Commission of the International Society of Forensic Genetics (ISFG): an update of the recommendations on the use of Y-STRs in forensic analysis. *Int. J. Legal Med.* 119: 1-10.
- Gusmão L, Sanchez-Diz P, Calafell F, Martin P, Alonso CA, Alvarez-Fernandez F, Alves C, Borjas-Fajardo L, Bozzo WR, Bravo ML, Builes JJ, Capilla J, Carvalho M, Castillo C, Catanesi CI, Corach D, Di Lonardo AM, Espinheira R, Fagundes de Carvalho E, Farfan MJ, Figueiredo HP, Gomes I, Lojo MM, Marino M, Pinheiro MF, Pontes ML, Prieto V, Ramos-Luis E, Riancho JA, Souza Goes AC, Santapa OA, Sumita DR, Vallejo G, Vidal Rioja L, Vide MC, Vieira da Silva CI, Whittle MR, Zabala W, Zarrabeitia MT, Alonso A, Carracedo A, Amorim A (2005b)** Mutation rates at Y chromosome specific microsatellites. *Hum Mutat.* 26(6):520-8.
- Kittler R, Erler A, Brauer S, Stoneking M, Kayser M (2003)** Apparent intrachromosomal exchange on the human Y chromosome explained by population history. *Eur. J. Hum. Genet.* 11(4): 304-14.
- Mulero JJ, Chang CW, Hennessy LK (2006)** Characterization of the N+3 Stutter Product in the Trinucleotide Repeat Locus DYS392. *J. Forensic Sci.* 51(5): 1069-1073.

Rodig H, Grum M, Grimmecke HD (2007) Population study and evaluation of 20 Y-chromosome STR loci in Germans. *Int. J. Legal Med* 121(1): 24-27.

Stein B, Willuweit S, Nagy M, Vogt PH, Roewer L (2005) AZF deletions of the Y chromosome and failed amplification of commonly used Y-STRs. 21st Congress of the International Society for Forensic Genetics. Ponta Delgada, Portugal.

Szibor R, Edelmann J, Hering S, Plate I, Wittig H, Roewer L, Wiegand P, Cali F, Romano V, Michael M (2003) Cell line DNA typing in forensic genetics – the necessity of reliable standards. *Forensic Sci. Int.* 138 37-43.

Notes

Notes